

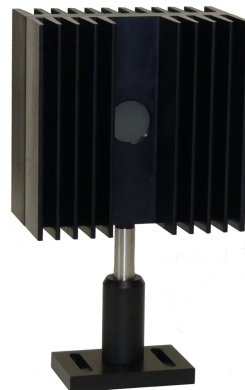

Power and Energy Measurement for Lasers

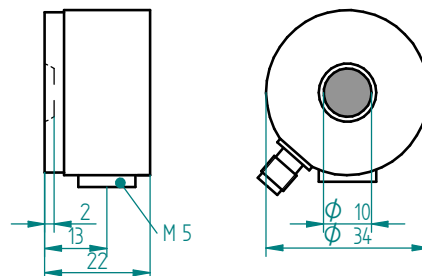

THz-Detectors

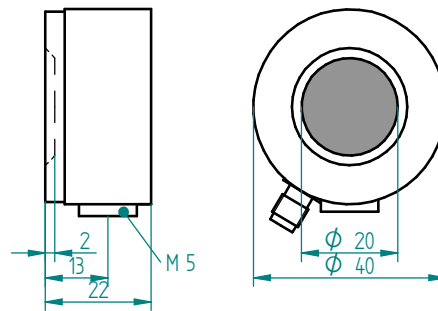
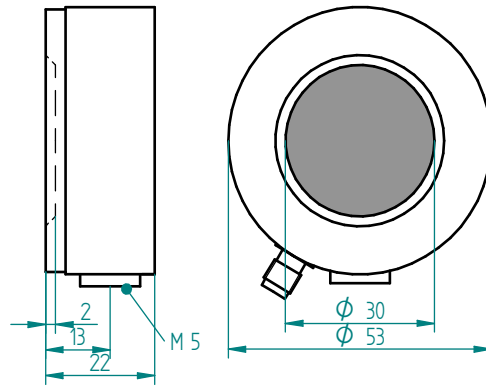

THz-Detectors

Basics

These types of pyroelectric detectors are optimized for application in THz region. The detectors are small, have a large active area and a short response time.

The basic principle of pyroelectric detection is that the radiation pulse coming from a pulsed laser or a chopped cw-laser is absorbed in an absorber sheet. From there the heat energy is transferred to the pyroelectric sensor material by heat conduction. For all types of THz detectors a broadband metallic absorber is used. For realizing broadband absorption a partial absorption of nearly 50 % is realized, whereas 25% are reflected and the 25% transmitted radiation is absorbed in a dump. A temperature change of the sensor material leads to a generation of a free charge at two opposite surfaces of the sensor.

There are two possibilities to detect this signal:

- Using a **voltage detection** with a high load resistor for energy measurement
- Using a **current detection** with transimpedance amplifier for power measurement

Absorption

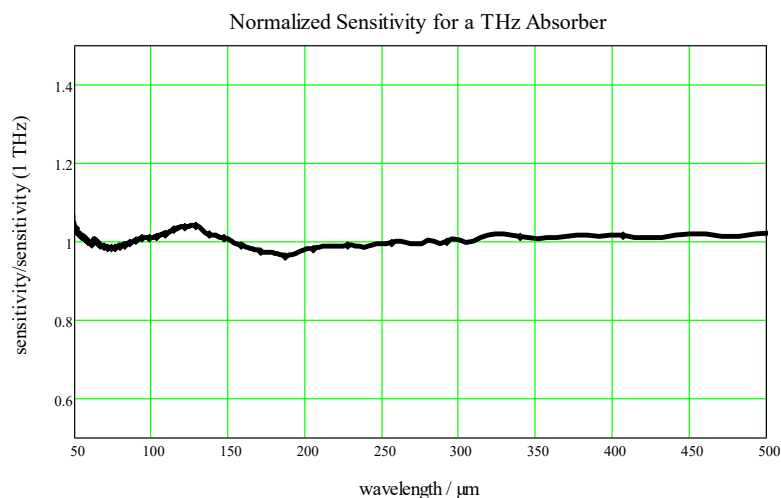

The figure to shows the sensitivity of the pyroelectric detectors normalized with the sensitivity at 1 THz. Between 200 and 500 μm the sensitivity changes within 2%. Additional measurements and comparisons at wavelengths up to the cm-range are done with same excellent absorption behaviour.

Calibration

All detectors will be calibrated at 1.4 THz in combination with a current preamplifier (calibrated in V/W) at the PTB Berlin. According to the physics of absorption the sensitivity should be valid also for longer wavelengths. A nearly wavelength independent absorption behaviour up to 600 μm is confirmed by the PTB. An experimental confirmation for longer wavelengths (up to 3 mm) is available now.

The calibration of the detector is done without any window. Under these conditions any movement of air must be avoided. We deliver the detector with a protection cap having a THz transparent insert. This cap can be used for avoiding any type of disturbance from moving air or fans.

THz - Detector as Powermeter

This is the typical application for this kind of detectors. The THz detection system consists of a detector and a current pre-amplifier CPA (see page 20). It is optimized for application in connection with cw- lasers and a chopper.

The response of a pyroelectric detector can be very fast, but for a reduction of noise the bandwidth of the preamplifier is limited. A further reduction of noise is possible by using detectors with smaller active area. The actual bandwidth depends on the frequency limit and is given in the preamplifier datasheet. Two possibilities for a Signal/Noise improvement for continuously repeated signals are often used:

- Averaging
- Lock in amplification.

	THz 10	THz 20	THz 30	THz 10 HS	THz 20 HS
Diam. of active area [mm]	10	20	30	10	20
Thermal time constant [ms]	50	50	50	20	20
Max. power density [mW/cm ²]	15	15	15	5	5
Typical current sensitivity [μAW]	0.5 .. 0.6	0.5 .. 0.6	0.5 .. 0.6	1.5 .. 1.8	1.5 .. 1.8
Rise time * [μs]	100	700	2000	<100	350
Max. chopper rate* [Hz]	500	200	80	1 kHz	500 Hz
Working range*	8μW .. 10mW	10μW .. 10mW	20μW .. 100mW	1μW .. 1mW	1μW .. 5mW

*Rise time, max. chopper rate and working range strongly depending on the bandwidth of the amplifier. For typical applications. As lower the bandwidth, as lower the noise and lowest measurable power, but maximum chopper frequency sinks. Amplifiers for high repetition rates or low power application are available on request.

Examples for detection limits for preamplifier CPA with different bandwidths

Detector	Preamplifier $f_{in} = 17$ Hz	Preamplifier $f_{in} = 70$ Hz	Preamplifier $f_{in} = 200$ Hz	Preamplifier $f_{in} = 4$ kHz
THz 10	8 μW	20 μW	25 μW	100 μW
THz 20	10 μW	25 μW	35 μW	130 μW
THz 30	20 μW	35 μW	140 μW	180 μW

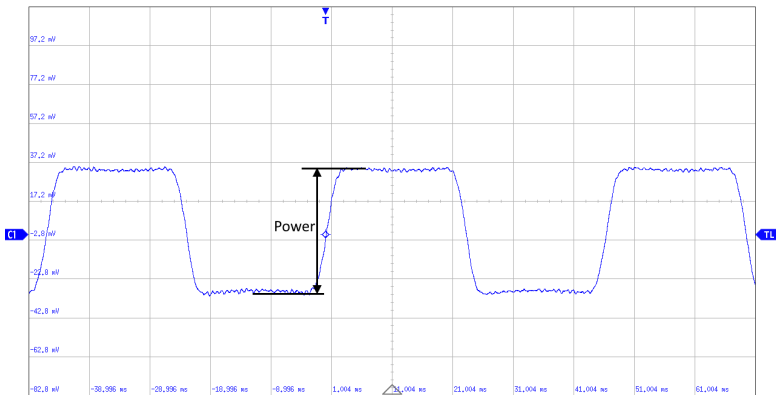

Typical oscillogram of a THz20 in combination with a current amplifier CPA and a chopper as a power meter

THz - Detector as Joulemeters

For many application the pyroelectric sensors can be used directly in combination with an oscilloscope ($R_i = 1\text{ M}\Omega$) or the voltage preamplifier VPA (see page 20). For these conditions the parameters (min. detectable energy and the max. rep. rate) are limited. In combination with a preamplifier these parameters can be extended. Some typical parameters for detectors without preamplifier are summarized in the following list:

In dependence on sensor diameter and rep.- rate sensitivities up to 10^6 V/J can be realized. Max. rep. rates as high as 1000 pps and min. detectable energies in the order of 50 nJ are possible. Please ask for more information.

The use of the HS types is not recommended for energy measurement, as the sensitivity is significantly reduced due to the significantly higher sensor capacity.

	Sensitivity /V/J	Min. detect. energy / μJ	Max. rep. rate
THz 10	>500	0.5	30
THz 20	>200	1	25
THz 30	>20	2	20

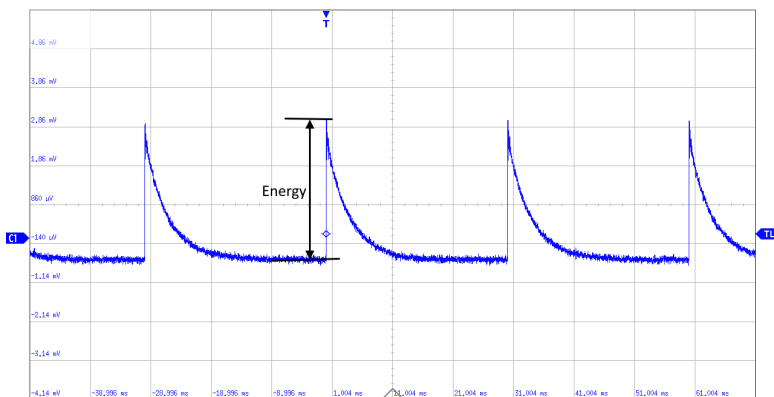

Typical oscillogram of a THz20 in combination with a voltage amplifier VPA as an energy meter

Current Preamplifiers CPA

The current preamplifier is necessary to realize a power measurement of the incoming radiation. The amplifier consists of an IC as transimpedance amplifier at the input side and two further voltage amplifier stages. There are some additional components for a noise reduction and offset regulation. In praxis the maximum amplification is limited by the cut off-frequency. Highest amplification can only be realized for small frequency intervals. For THz detectors in combination with a chopper often the upper frequency is limited to values less than 50 Hz. For such amplifiers conversion factors between 10^7 V/W and 10^{10} V/W can be realized.

The sensitivity of the combination detector and preamplifier is determined by multiplication of the current sensitivity of the detector and the amplification of the current amplifier (e.g. detector 10^{-6} A/W and CPA 10^9 V/A leads to a total sensitivity : 10^{-6} A/W* 10^9 V/A= 1000 V/W). The amplification can be set by a switch.

The amplification can be set by a 4-step switch: e.g. 10^7 ... 10^{10} V/A ; the bandwidth is fixed* to e.g. 50Hz or 250 Hz. The detection limit depends on the amplification, the bandwidth and detector diameter.

Amplification and bandwidth can be adapt on your requests.

Specifications:	
Connectors:	BNC
Amplification:	10^7 , 10^8 , 10^9 , 10^{10} V/A
Bandwidth:	50 Hz - 250 Hz, switchable
Power supply:	5 V, Micro-USB



Voltage Preamplifiers VPA

For many application the pyroelectric sensors can be used directly in combination with an oscilloscope ($R_i = 1$ M Ω). For these conditions the parameters (min. detectable energy and the max. rep. rate) are limited. In combination with a preamplifier these parameters can be extended. In combination with a preamplifier sensitivities up to 10^6 V/J can be reached and the minimum detectable energy is in the order of 50 nJ.

Specifications:	
Connectors:	BNC
Amplification:	10, 100, 1000 or 10000
Bandwidth:	5 kHz
Input Impedance:	1 M Ω
Power supply:	5 V, Micro-USB



Optical Chopper

The chopper is needful to modulate continuous radiation to measure the power in combination with a pyroelectric detector and especially for THz detectors. We use a microprocessor controlled PID controller to offer an easy handling and stable frequency. The frequency can set with a keypad. To repeat measurements at different chopper rates is very easy. Additionally it is possible to control and read out the frequency via USB port.

In standard configuration replaceable chopper discs have a diameter of 100mm. For alternatively operation, for instance in combination with a Lock In amplifier a sync out signal is generated.

One chopper disc with two slots, the most useful for our THz detectors, is included.

Chopper disc	No. of slots	Chopper frequency
CD100-2	2	5 - 120 Hz
CD100-5	5	12 - 300 Hz
CD100-10	10	25 - 600 Hz
CD100-20	20	50 - 1200 Hz

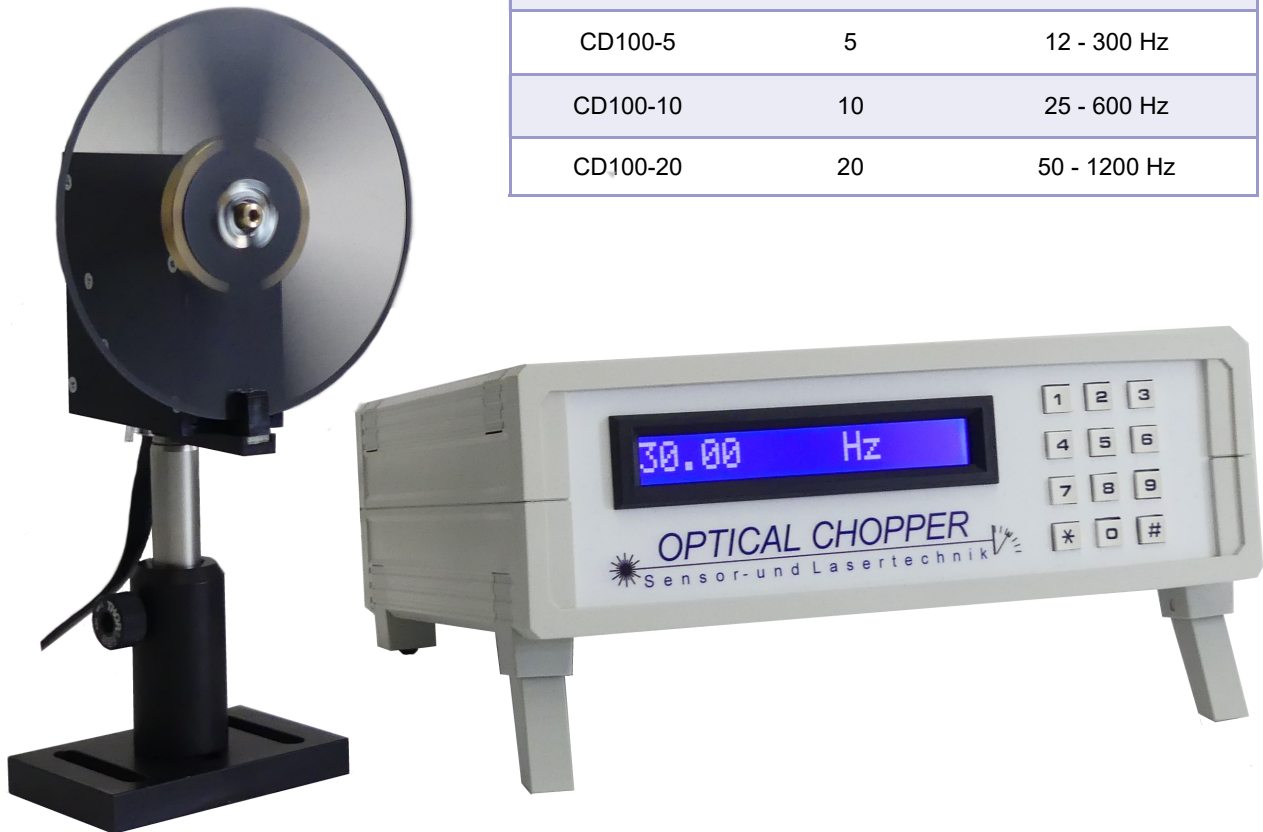

Parameters	
Diameter of chopping discs	100 mm
Frequency drift and jitter	< 1%
Sync Out compatibility	TTL/CMOS
Supply	85 VAC - 240 VAC; 50 - 60 Hz

SLT Sensor- und Lasertechnik GmbH

Freiheitstr. 124-126
15745 Wildau
Germany

Tel.: +49 3375 5257201
Fax: +49 3375 5257203

www.pyrosensor.de
service@pyrosensor.de